

Product Instruction

- Green Power:

Green power sources are regarded as new & pure sources generated by modern technology such as solar power, wind power, tidal power and geothermal power, etc. This learning kit is equipped with solar power cell, for users to learn the application of green energy technology, comprehend energy transformation and finally manage green energy more efficiently.
- Solar power module:

Get different voltage & current, comprehend characteristic curve of I/V, V/P and MPP and learn solar power transformation through solar power module.
- GP-6W Green Power Learning Kit :

GP-6W is a basic green energy transduction kit of solar power. It is equipped with a MCU for users to learn MPPT (Maximum Power Point Tracking) algorithm. Users know more about the regeneration of green power through changing MPPT algorithm.



Standard Accessories

1. Main unit.....x1
2. CD.....x1
(included user's manual, teaching book, source code, example)
3. No. 4 rechargeable battery ...x4
4. Adaptor 12V 0.5A, positive pole inside.....x1
5. USB cable.....x1
6. 10cm 2pin cable with 3.96mm terminal.....x1
7. 30cm 2pin cable with 3.96mm terminal.....x2
8. 34cm 3pin cable with 3.96mm terminal.....x5

Optional Accessories:

1. Halogen lamp, 250W
2. Wind power generation kit LP-2025

Features

1. Portable suitcase design kit. User can utilize sunlight or rechargeable battery to operate the system in the outdoors.
2. Application of MPPT algorithm.
3. LCD shows input/out voltage, current and power value.
4. DC TO DC CONVERTER Module for learning experiment of output transduction.
5. DC TO AC INVERTER Module for learning experiment of output transduction.
6. Learn the regeneration use of solar power through Charging Module.
7. Battery charging control function: VBAT(Charging Voltage), IBAT(Charging Current) and VMPP(Maximum Power Point) can be set during battery charging
8. Learn the regeneration use of solar power through Load Module. EX: LED shining.
9. Wind and solar modules have their own simple voltage LED display to determine the current value of the input voltage.
10. The kit is based on Open Design. User can change operating procedure during experiment.

Content of Teaching Book

- Ch 1: Instruction of green power
- Ch 2: Instruction of learning kit
- Ch 3: Instruction of software development tool
- Ch 4: Learn C language
- Ch 5: Feature and basic experiment of MPC82G516
- Ch 6: Control of LCM display
- Ch 7: Control of analog to digital
- Ch 8: Control of PWM
- Ch 9: Theory of DC TO DC
- Ch10: Control of battery charging & discharging
- Ch11: MPPT algorithm
- Ch12: Design of DC TO AC

Block Diagram of Solar Power System

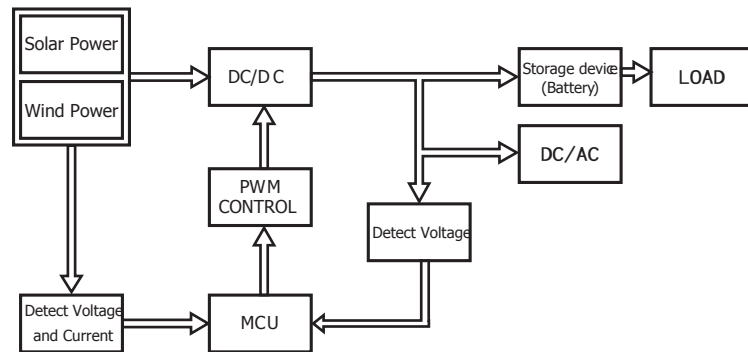

Product Specification

Output Power Of Solar	6W
Output Voltage of Solar Power	8V (MAX)
Output Current of Solar Power	780mA (MAX)
Communication Interface	USB
System Power	DC 9V~12V/500mA
Dimension	335 x 240 x 75mm
Weight	2.5 kg

Content of Experiment

Teach users the way to connect different module and design operating mode of each module so that users can comprehend the basic principle and application of solar power battery.

1. Observe I/V, V/P and MPP characteristic curve of solar power module
2. Set the output (I/V) of solar power module according to the incident angle
3. Design of DC TO DC CONVERTER Module
4. Experiment of DC TO AC INVERTER Module
5. Experiment of basic load and observe the I/V of solar power module
6. Charging and discharge function of battery
7. MPPT algorithm
8. Integrate all experiments above so users can exactly know regeneration and use of green power